

# Embedded Bluetooth Module - FB155BC



## ABOUT FB155BC version 2.0

Class 1, BT 2.0 Support

8PINs Header type

Chip Antenna

AT Command provided

**(C) Copyright FIRMTECH Co., Ltd. 2005**  
**All rights reserved**

The products and operation descriptions contained herein shall be protected by copyright law.

Any part or whole of products or operation description shall not be copied, reproduced, translated, nor transformed into readable form by electronic device or machines, without prior consent in writing by FIRMTECH Co., Ltd.

There might be some misprinting or technical faults in the products and operation description which are subject to change without prior notice.

**FIRMTECH Co., Ltd.**

Room 720, C Unit of Sigma Officetel, 18,  
Kumi Dong, Bundang Ku,  
Sungnam City, Kyonggi Do.

Homepage : [www.firmtech.co.kr](http://www.firmtech.co.kr)

Marketing Inquiry : [contact@firmtech.co.kr](mailto:contact@firmtech.co.kr)

Technical Support Inquiry : [techsupport@firmtech.co.kr](mailto:techsupport@firmtech.co.kr)

Tel : +82-31-719-4812

Fax : +82-31-719-4834

## What is Bluetooth?

### 1. Features of Bluetooth

- 1) Objectives of Bluetooth : To Realize Wireless Communication for Short Distance with Low Power Consumption, High Reliability, and Low Cost.
- 2) Frequency in Use: To Use ISM(Industrial, Scientific, Medical) Band which does not require any permission to use.
  - 2.400 – 2.4835 GHz, 79 channels
  - 2.465 – 2.4835 GHz, 23 channels (in France)
- 3) Transmission Rate : 1Mbps ~ 3Mbps
- 4) Transmission Output : 1mW(10m, Class2), 100mW(100m Class1)
- 5) Network Configuration : Configured with Master and Slave relation. A Bluetooth unit shall allow simultaneous connections up to 7 devices (in case of ACL).
- 6) Reliability : To Guarantee stable wireless communication even under severe noisy environment through adopting the technique of FHSS (Frequency Hopping Spread Spectrum).

### 2. Operation of Bluetooth

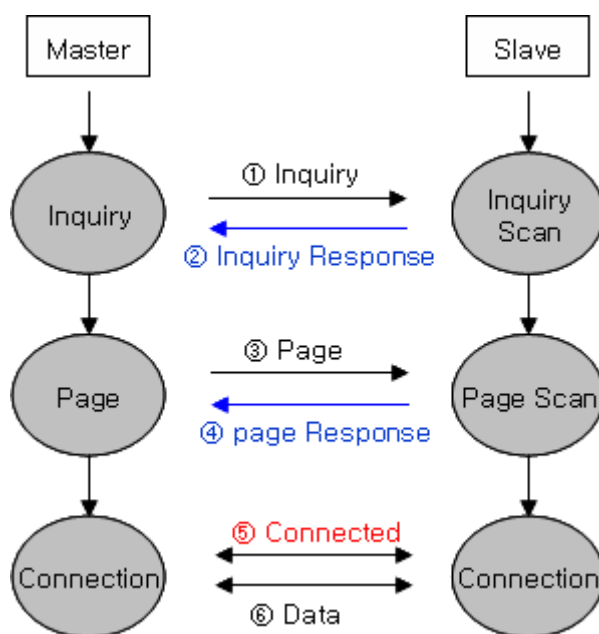

<Figure 0-1 Operation of Bluetooth>

- 1) Once the Master will inquire the Slave, the Slave will respond to the inquiry to the Master.
- 2) When the information of Slave will agree with that of the Master, the interconnection will be achieved to transmit the data.

## **Products Overview**

FB155BC has been developed to replace the previous RS232 Cable system with wireless communication system to use.

### Major Features of FB155BC

1. Bluetooth Specification 2.0 Support
3. Easily applicable to the Product with 8Pins Header type
4. Support AT Command, and capable to control FB155BC by using AT Command.
5. Easy to connect to use with Bluetooth PDA, Bluetooth USB Dongle, etc.
6. Stable Data Transmission / Receipt

**※ We request the new users of FB155BC to read the information on this description carefully before they start to use the products.**

**■ LIST OF CONTENTS**

**1 PRELIMINARY USAGE OF PRODUCT ..... - 7 -**

**1-1 PRODUCT COMPONENTS..... - 7 -**

        1-1-1 FB155BC ..... - 7 -

**2 PERFORMANCE OF PRODUCTS ..... - 8 -**

**3 CURRENT CONSUMPTION ..... - 9 -**

**4 PRODUCT APPEARANCE ..... - 10 -**

**4-1 FB155BC DIMENSION ..... - 10 -**

**4-2 FB155BC PIN ASSIGN ..... - 10 -**

**5 INTERFACE (PIN CONNECTION) ..... - 12 -**

**5-1 WITHOUT FLOW CONTROL ..... - 12 -**

**5-2 WITH FLOW CONTROL..... - 12 -**

**6 PRELIMINARY PRODUCT COMPONENTS..... - 13 -**

**7 PC INTERFACE BOARD (JIG BOARD)..... - 14 -**

**8 HOW TO COMPLETE PC CONFIGURATION ..... - 15 -**

**8-1 PC CONFIGURATION USING CONGFIG TOOL ..... - 15 -**

**8-2 PC CONFIGURATION USING SERIAL COMMUNICATION(HYPER TERMINAL) PROGRAM..... - 19 -**

        8-2-1 To execute Hyper Terminal..... - 19 -

        8-2-2 How to Use PC Configuration Menu..... - 23 -

## **1 PRELIMINARY USAGE OF PRODUCT**

### **1-1 PRODUCT COMPONENTS**

#### 1-1-1 FB155BC

- FB155BC module
- On-board chip antenna

#### 1-1-2 PC Interface Kit

- PC Interface board(Jig board)
- Serial extension cable
- DC Power Adapter
- USB Cable
- CD

If you find any of above components is defective, or not included in the package, please contact the seller you purchased.

## 2 PERFORMANCE OF PRODUCTS

Part	Specification
Bluetooth Spec.	Bluetooth Specification 2.0 Support
Communication distance	100 M
Frequency Range	2.4 GHz ISM Band
Sensitivity	-83dBm (Typical)
Transmit Power	4dBm (Typical)
Size	18 x 20 mm
Support Bluetooth Profile	GAP, SPP
Input Power	3.3V
Current Consumption	48 mA (Max)
Operating Temperature	-10°C - 50°C
Communication Speed	1,200bps – 230,400bps
Antenna	Chip Antenna
Interface	UART (TTL Level)
Flow Control	RTS, CTS, DTR, DSR support

<Table 2-1 FB155BC Performance>

### 3 CURRENT CONSUMPTION

Status		Current Consumption (mA)		
		MAX	MIN	AVG
Standby		3	0	<b>1</b>
Inquiry scan & Page scan (Slave)		48	0	<b>22</b>
Page scan (Slave)		12	0	<b>1</b>
Inquiry (Master)		45	39	<b>42</b>
Connected	Slave	24	18	<b>21</b>
	Master	9	0	<b>4</b>
Data Transmission	Slave	30	24	<b>28</b>
	Master	27	18	<b>21</b>
Data Reception	Slave	33	21	<b>26</b>
	Master	33	21	<b>27</b>
Data Transmission/Reception	Slave	33	27	<b>29</b>
	Master	33	21	<b>28</b>
Power save	Slave	6	0	<b>1</b>
	Master	9	0	<b>2</b>

<Table 3-1 CURRENT CONSUMPTION>

#### - TEST CONDITIONS

Baud Rate : 9600 bps, Input Voltage : DC 5V

The power consumption will change depending on transmission speed and volume of data.

## 4 PRODUCT APPEARANCE

### 4-1 FB155BC Dimension

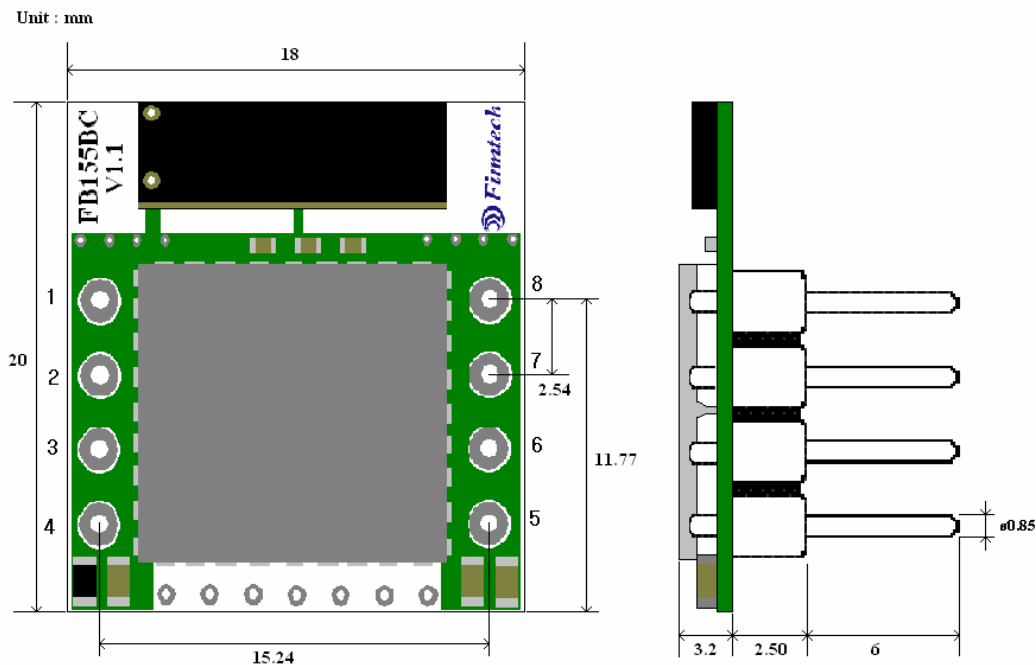

<Figure 4-1 FB155BC Dimension>

### 4-2 FB155BC PIN Assign

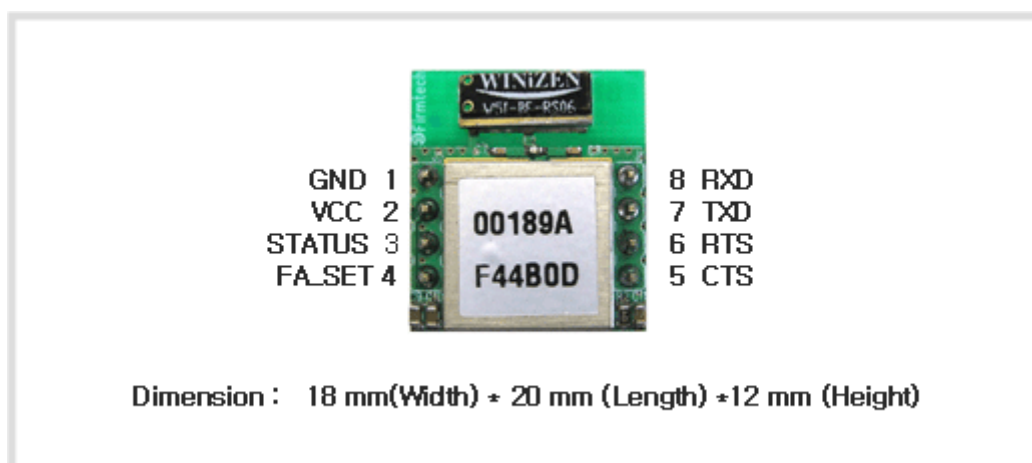

<Figure 4-2 FB155BC PIN Assign>

PIN NO.	NAME OF SIGNAL	FEATURES	INPUT/OUTPUT	SIGNAL LEVEL
1	GND	Ground		
2	VCC	3.3V DC	Input	
3	STATUS	STATUS LED	Output	TTL
4	FA_SET	Factory Reset	Input	TTL
5	UART_CTS	UART Clear To Send	Input	TTL
6	UART_RDS	UART Ready To Send	Output	TTL
7	TXD	Transfer Data (Data out)	Output	TTL
8	RXD	Received Data (Data in)	Input	TTL

&lt;Table 4-1 Pin Description&gt;

- Hard Reset(Factory Reset)

To return to the factory reset, input LOW signal (0V) to FA\_SET (No 2 PIN) for more than 2 seconds then all the set value shall be changed to the initial factory set value.

- STATUS port

To be used to monitor the status of FB155BC.

To keep LOW(0V) when the two devices are communicable since the connection between wireless range is smoothly made.

In standby mode for connection with Bluetooth, or connection trial, or searching for around Bluetooth device will repeat LOW and HIGH.

- UART\_CTS/UART\_RTS

When the flow control is not used, non connection will not affect the operation of FB155BC.

## 5 INTERFACE (PIN CONNECTION)

### 5-1 Without Flow Control

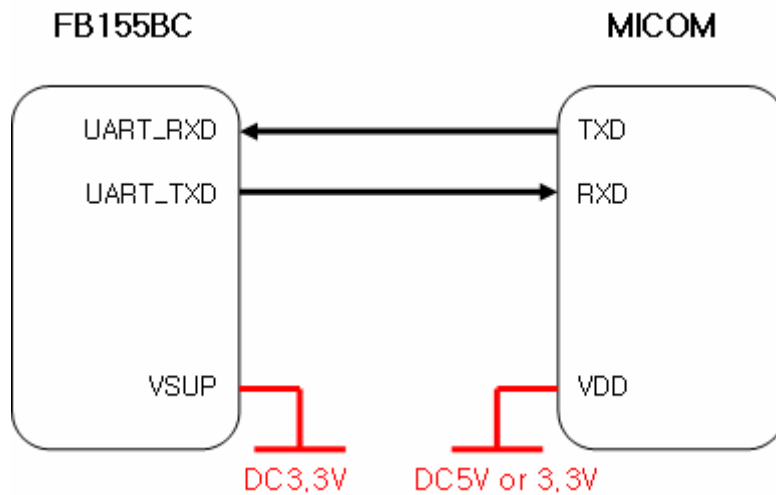

<Figure 5-1 : Pin Connection without Flow Control >

### 5-2 With Flow Control

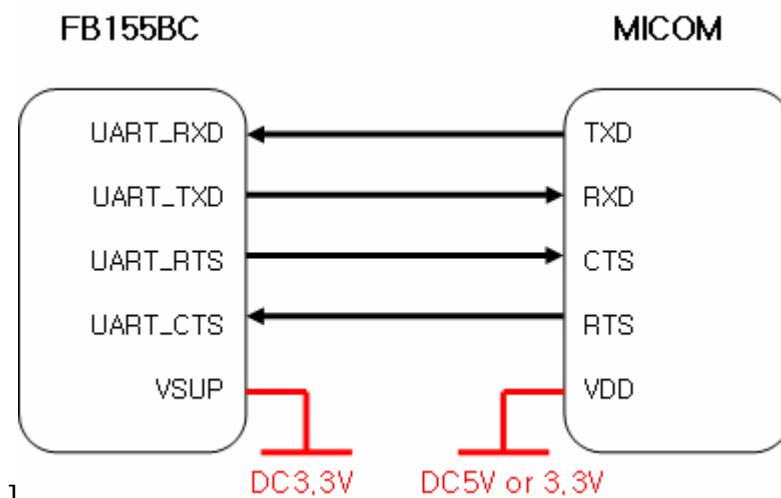

]

<Figure 5-2 : Pin Connection Diagram with Flow Control >

## 6 PRELIMINARY PRODUCT COMPONENTS

The preliminary value of product is set as on the <Table 6-1>.

Please be sure of basic set value and so on before using the product.

TYPE	SET VALUE
Device Name	FB155v.x.x.x
Pin Code(Pass key)	BTWIN
Uart(baud rate-data bit-parity bit-stop bit)	9600-8-N-1
ROLE	SLAVE
Connection Mode	MODE4 (AT command)
Debug char	0x02

<Table 6-1 : Preliminary Configuration Setting Value for FB155BC >

To change the configuration set value of FB155BC, connect FB155BC to the PC using the PC Interface board then, you may change using the PC software (such as Window Hyper Terminal, FIRMTECH's PC configuration program). With MICOM, you may change the set value by using AT command.

**Note :** For details on the setting change, please refer to 8 How to complete PC Configuration.

## 7 PC Interface Board (Jig Board)

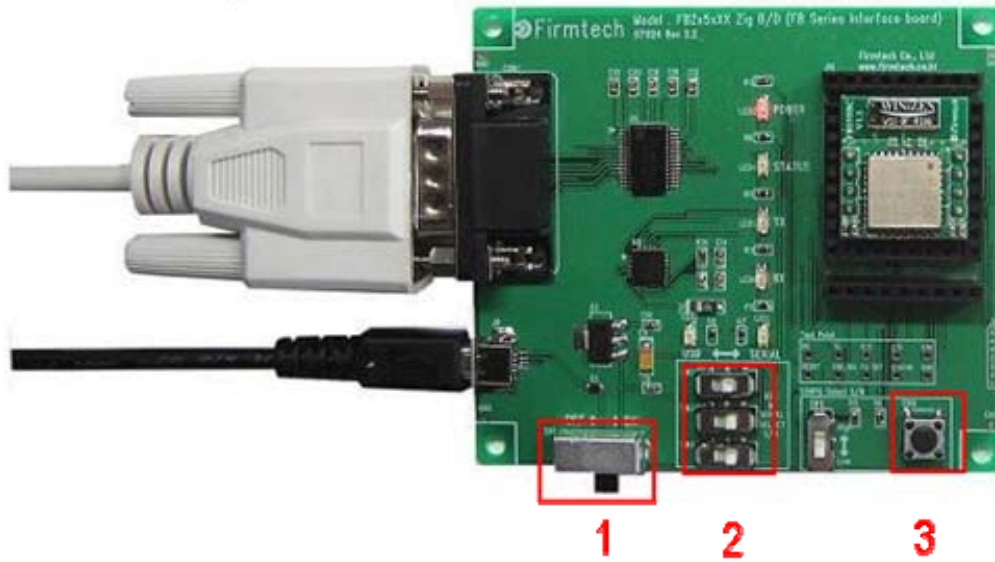

1 Power ON/OFF Switch

2 USB / RS232 Interface Select Switch

3 FA Set Button

<Figure 7-1 : FB155BC Interface Board(Jig Board)>

## 8 How to Complete PC Configuration

The following PC Configuration shall be explained on the assumption that FB155BC is connected with PC Interface Board(Jig board). If it is connected to MICOM, then you can change the set value by using AT command language with reference to Attachment AT command language.

Components for PC Configuration

- FB155BC module
- PC Interface Kit

The PC Configuration could be processed with two significant ways.

First one is to use Config tool provided by FIRMTECH Co., Ltd.

Second one is to use serial communication program (Hyper Terminal, minicom) providing OS.

The respective way of setting is as follows.

### 8-1 PC Configuration using Congfig tool

- (1) Connect FB155BC to PC Interface Board, then connect to COM port(Serial port) of PC.
- (2) Set Config Select Switch of PC Interface Board OFF and then turn the power ON.
- (3) Execute Config tool.



<Figure 8-1 : config tool main Display>

(4) Select “CONNECT”( <Figure 8-1> Blue Lined) on the main display.

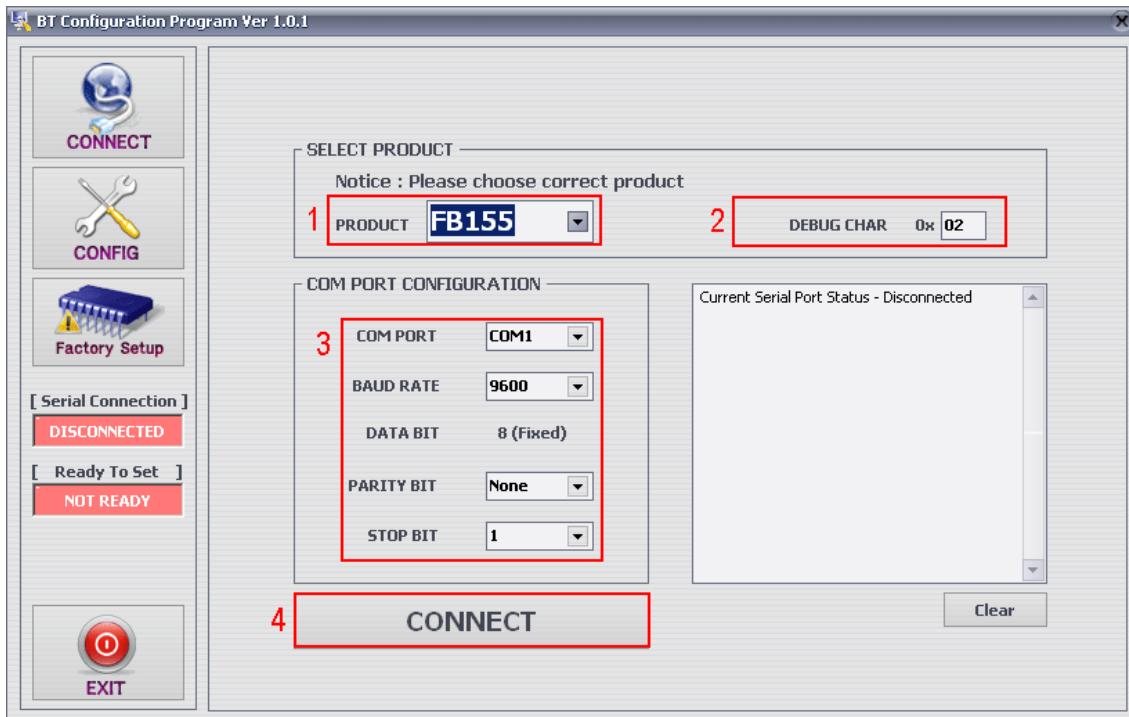

1 Select Product : Name of Product in Use

2 DEBUG CHAR : Default is **0x02**. (Appendix : Refer to details of PC Configuration)

3 Set Serial Port : Default is BAUD RATE : **9600**, PARITY BIT : **None**, STOP BIT : **1**

<Figure 8-2 : config tool CONNECT Display>

(5) When the <Figure 8-2> appears, select each selective item of red lines box 1~3, then press connect (red box line 4) which will change Serial connection, Ready To Set (red lined box 1) into Green as shown on <Figure 8-3>. **(The selected value will be certified at the preliminary setting of product.)**

If the color does not change into green, please make sure of the Baud rate of product and re-execute the config tool.

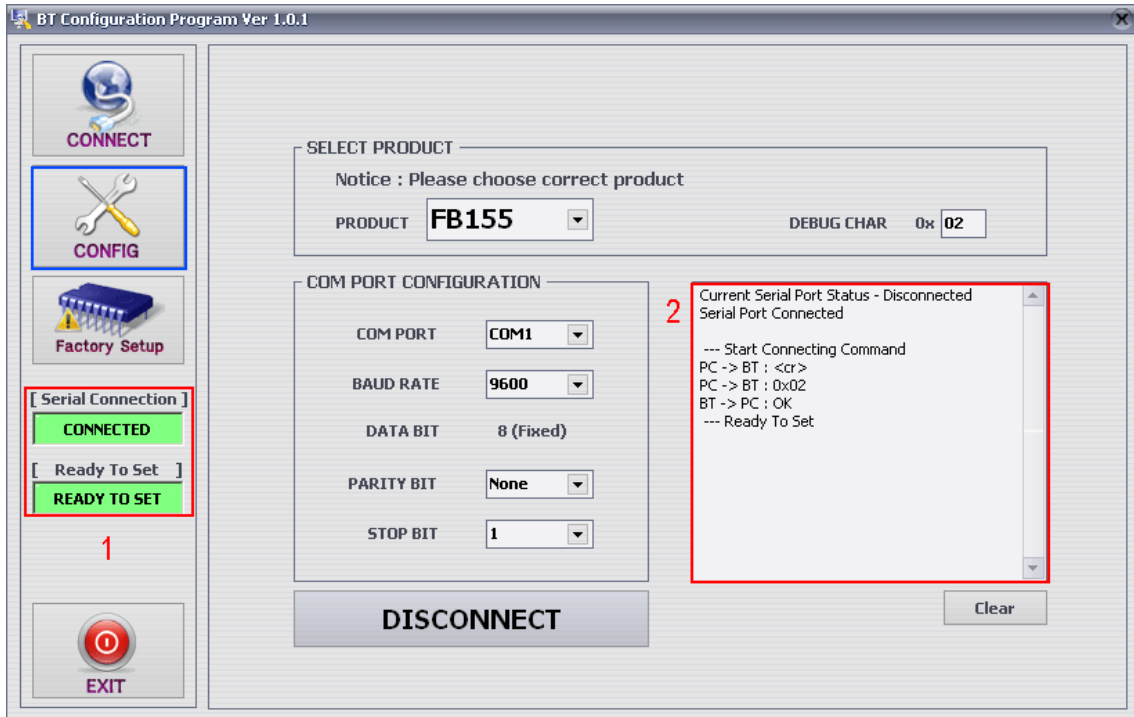

1 Serial Connection, Ready To Set : Show the connection status of Config tool and products

2 Status Message : Display the status of command language in progress

<Figure 8-3 : config tool connection display>

(6) After the product and config tool is connected properly, select CONFIG button(blue lined box) on Figure<8-3>, display like <Figure 8-4> will comes up to allow to configure the environment.

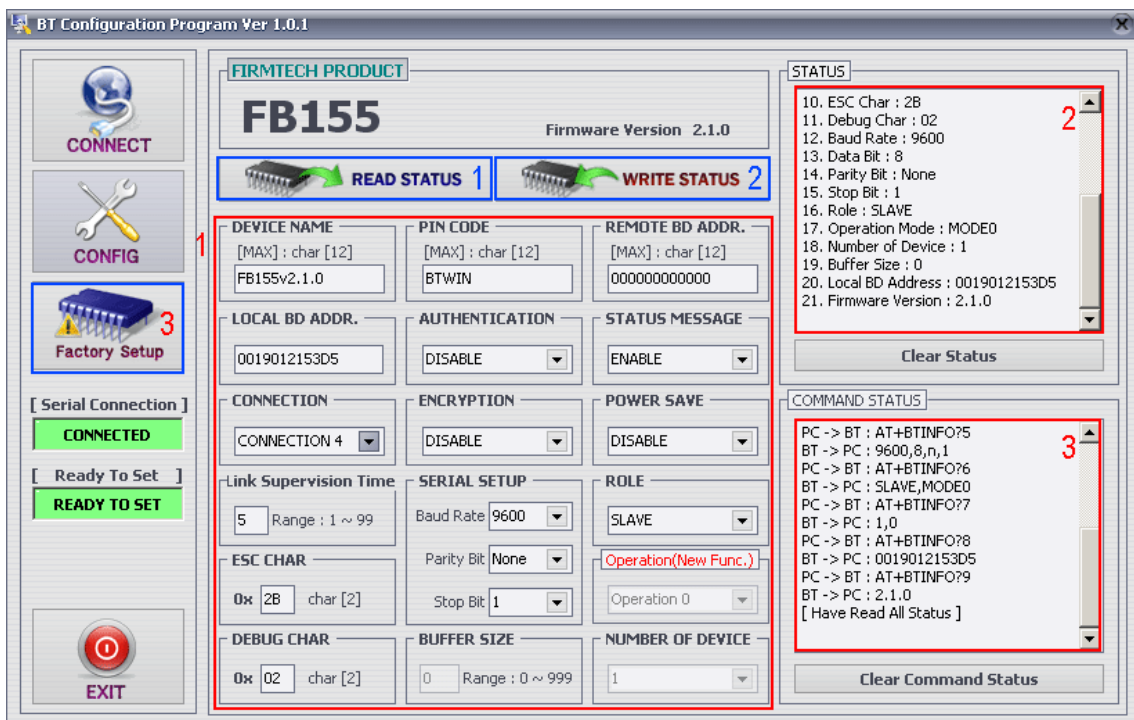

1 PC Configuration Window : Allow to select the PC configuration value of the product.

**2 Status Value** : Output the status value with the form of message.

**3 Status of Command Language** : Since the preliminary operation method is to use AT command, the progressed AT command language will output in the form of message.

**1 READ STATUS Button** : To read in the PC configuration set in the product.

**2 WRITE STATUS Button** : To store the value set in the PC configuration window into the product

**3 Factory Setup Button** : To reset all the PC configuration value to the factory set value.

<Figure 8-4 : config tool Device Configuration >

(7) To summarize the setting up the config tool, follow the procedures as under.

- To store the set value upon completion, please be sure to click WRITE STATUS button.
- Click READ STATUS to read in the stored configuration value to certify they are correct or not.
- If you want to set as the status first received, click Factory Setup to reset the first received value.
- Since the config tool was made based on AT command of the product, it is possible to represent the ongoing command language and its status at the form of status value and message window.

**Note** : Please refer to Appendix PC Configuration for detailed explanation.

## 8-2 PC Configuration using Serial Communication(Hyper Terminal) Program

### 8-2-1 To execute Hyper Terminal

To set up PC configuration using Hyper Terminal, following works will have to be done before power is authorized to the PC connected with the product.

To accomplish the PC configuration, serial communication program is required. Here Hyper Terminal will be used for explanation.

(1) Execute in the order of **[start]→[All Programs]→[Accessories]→[Communications]→[Hyper Terminal]**, then connection window will appear on which enter appropriate name and click.



<Figure 8-5 Set Up Window 1 of Hyper Terminal>

(2) When the <Figure 8-6> comes up, select the COM port connected to FB155BC, and clicks the Acknowledge button.



<Figure 8-6 Hyper Terminal Set Up Window 2>

(3) When Registration Information Window comes up as on <Figure 8-7>, select **Bit per second : 9600, Data bit : 8, Parity : none, Stop bit : 1, Flow control : none**, which will execute Hyper Terminal.

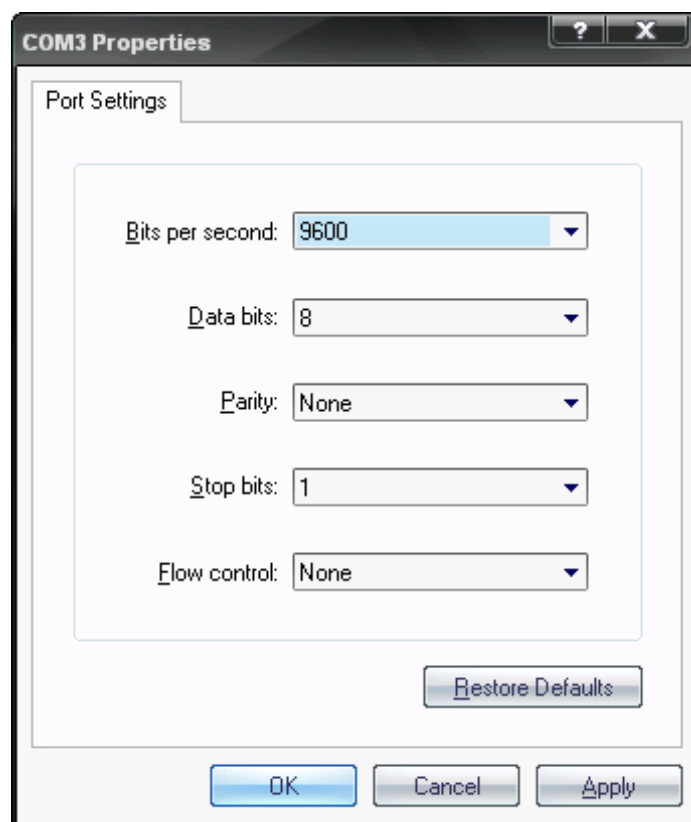

<Figure 8-7 Hyper Terminal Set Up Window 3>

(4) Basically, the Hyper Terminal does not show the entered character. To make sure of the

entered character, select **[File]→[Properties]** on the Menu, then registration information window will appear shown as on <Figure 8-8>, click the **ASCII Setup** button.

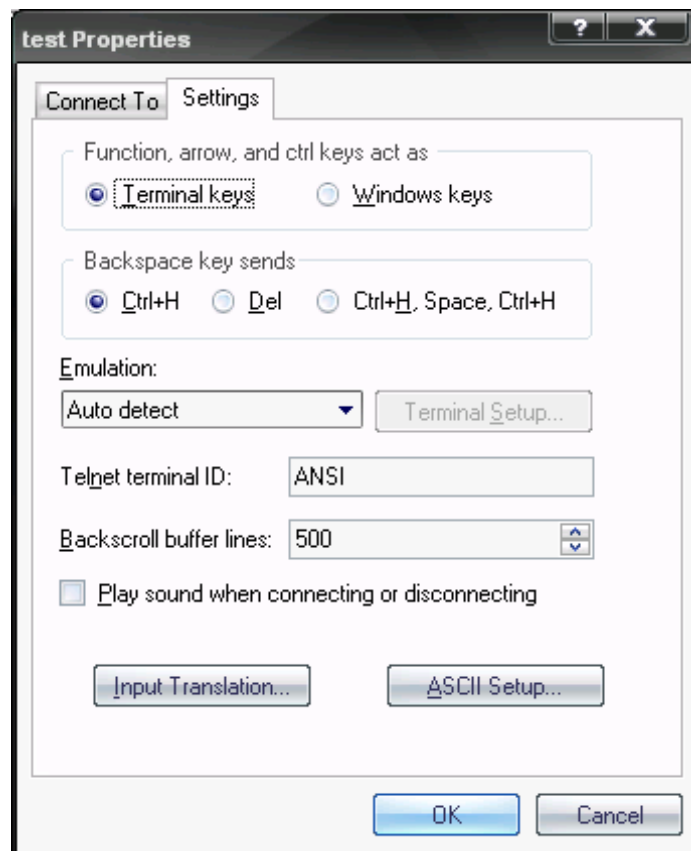

<Figure 8-8 Hyper Terminal Set Up Window 4 >

(5) As shown on <Figure 8-9>, **“Check Echo typed characters locally”** and come out pressing the acknowledge button. Now the Hyper Terminal program setting procedure is completed to use PC Configuration.

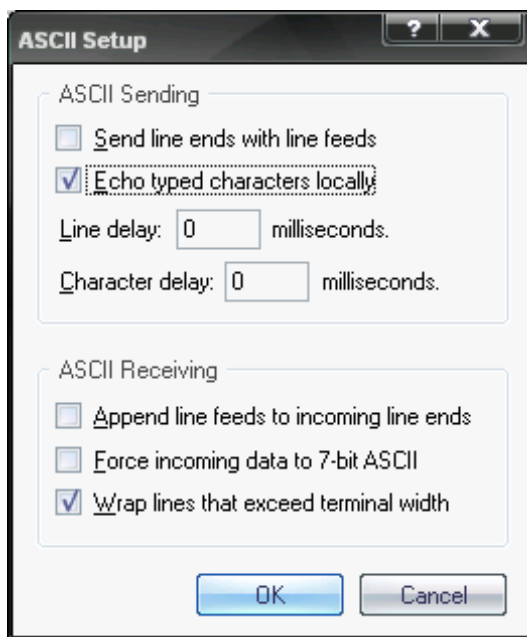

<Figure 8-9 : Hyper Terminal Setting Up Window5>

(6) To turn on the FB155BC from the condition which presses FA\_SET button is PC-configuration. As <Figure 8-10>, there will be PC-configuration message in Hyper-Terminal.

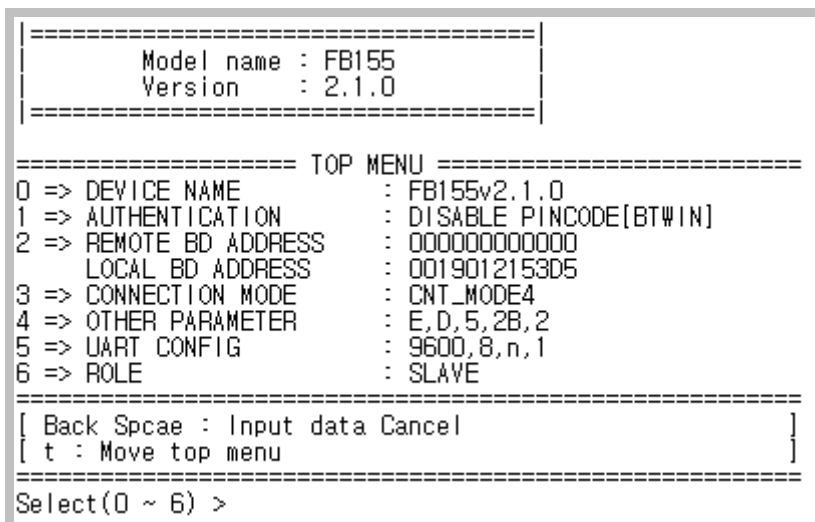

<Figure 8-10 : PC Configuration Menu>

## 8-2-2 How to Use PC Configuration Menu

The user will select the menu want to change. To select the menu, you may just select the number given on the left side.

For example : To change "DEVICE NAME", enter : **["0"]→[Enter]**

**Note :** At <Figure 8-10> condition, Pressing **FA Set** button for more than 2 seconds will reset all the configured values to the initial status (factory preset status).

Following is the order to use the menu.

- (1) The execution will only be executed by pressing the "Enter" key.
- (2) The small character "t" will always move to be positioned at upper side of the menu.
- (3) To move menu, use the number in the end of left side. Please be sure to "Enter" key upon completion of input.
- (4) "←" key is used to delete the entered character currently.
- (5) If the entered character is unreadable or is not supported at the appropriate menu, "Retry >" message will be output.
- (6) If the input message is more than 12 characters, "Overflow buffer" message will be output and then "Retry >" message appeared as well.

**Note :** Please refer to Appendix A PC Configuration for the detailed description on the configuration value.